

<https://electricassistcart.com>

海南金海芯科技控股有限公司

Hainan Jinhaixin Technology Holdings Co., Ltd

FomaTrade@outlook.com

产品手册

Product manual

FomaTrade@hotmail.com

编制(Edit): 李工 (li)

审核(Check): 杨工 (yang)

<https://electricassistcart.com>

批准(Approval): 杨先生 (R' yang)

FomaTrade@outlook.com

2024年01月01日

May, 01, 2024

-----由深圳市金海芯控股有限公司技术支持版权所有-----

FomaTrade@hotmail.com

Technical support by Shenzhen Jinhaixin Holdings Co., Ltd. All rights reserved

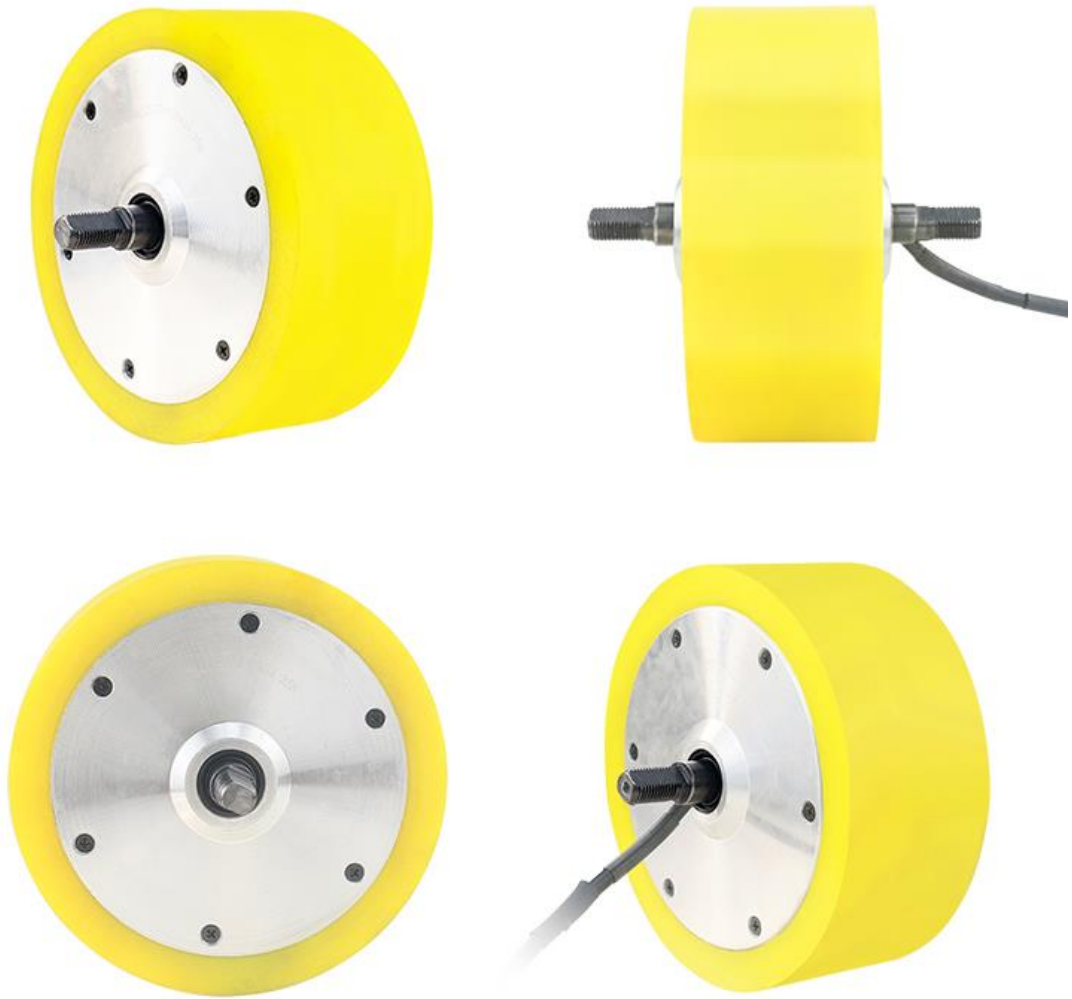

Product name: DC brushless gearless motor

FomaTrade@outlook.com

Specification Model: 8-inch twin shaft diameter

200mm tire width 68mm

Open 100mm (threaded type)

FomaTrade@hotmail.com

Product coded: FomaTrade-24078D005123036S1-003

Motor structure combination diagram:

<<MOTOR STRUCTURE>>

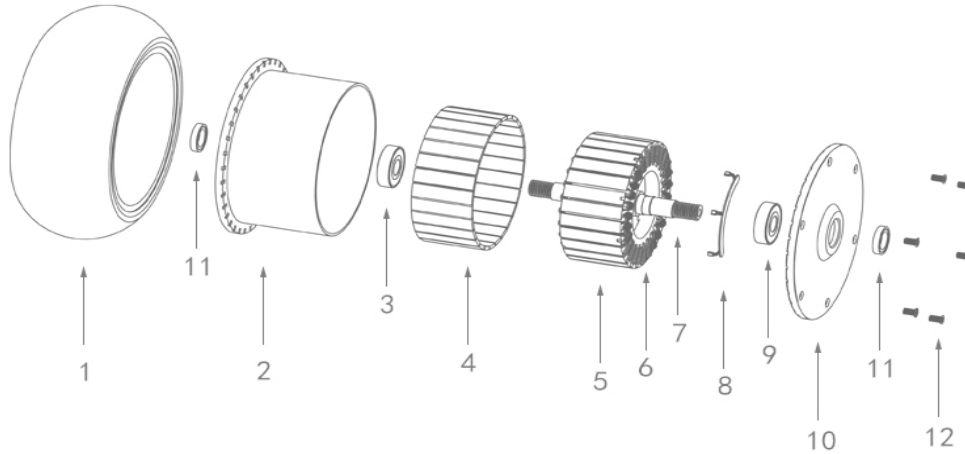

1: TIRE 2: WHEEL HUB 3: OUTER BEARING 4: MAGNET 5: STATOR 6: COPPER WIRE

7: FIXED SHAFT 8: SENSOR 9: OUTER BEARING 10: INNER END COVER 11: SCREW 12: WIPER RING

l.com

Motor dimensional drawing:

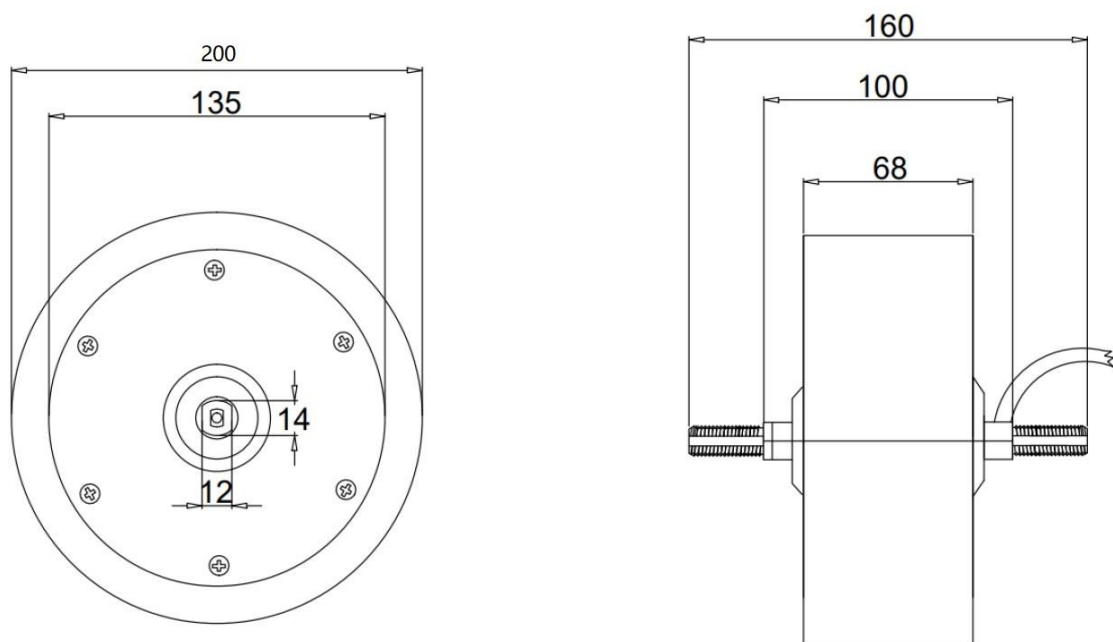

Test the data waveform: 24v

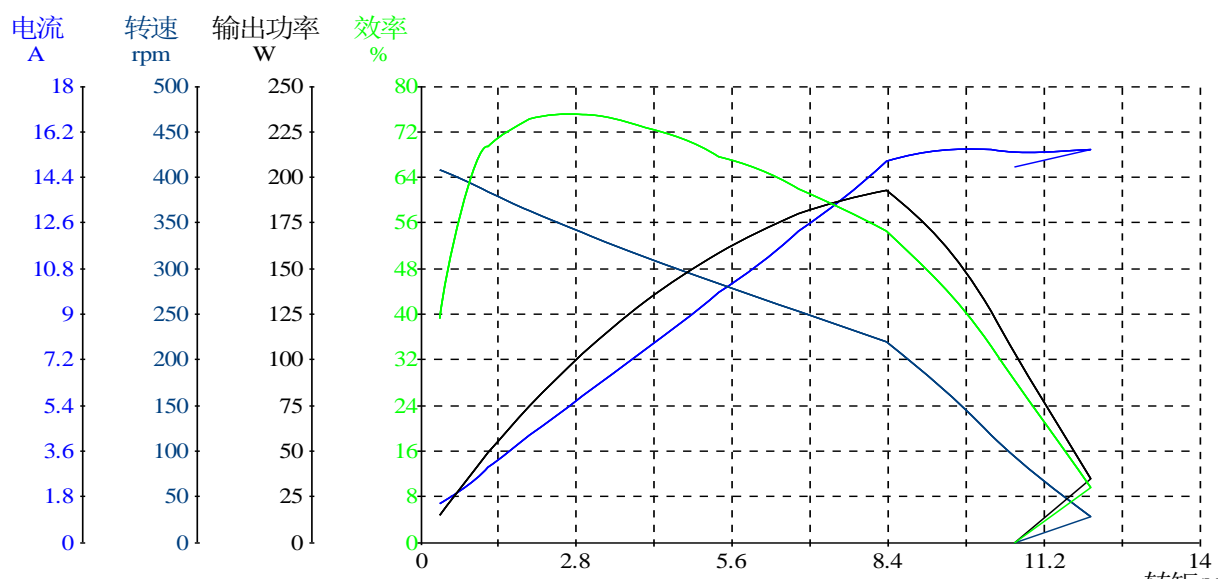

| 特征点 | 电压 | 电流 | 输入功率 | 转矩 | 转速 | 输出功率 | 效率 | 时间 |
|--------------------|-------|-------|-------|-------|-------|-------|------|-------|
| | V | A | W | N. m | rpm | W | % | S |
| 不加载点 (No_Load) | 24.09 | 1.534 | 36.93 | 0.34 | 408.6 | 4.46 | 39.2 | 0.000 |
| 最高效率点 (Eff_max) | 23.98 | 5.187 | 124.2 | 2.57 | 347.6 | 93.53 | 75.3 | 17.10 |
| 最大输出功率点 (Pout_max) | 23.69 | 15.03 | 354.8 | 8.38 | 220.1 | 193.2 | 54.5 | 43.26 |
| 最大转矩点 (Torque_max) | 23.66 | 15.49 | 366.4 | 12.05 | 27.8 | 35.08 | 9.6 | 55.33 |
| 结束点 (End) | 23.69 | 14.81 | 350.4 | 10.66 | 0 | 0 | 0 | 57.35 |

Dynamometer report data: 24v

| 序号 | 电压 | 电流 | 输入功率 | 转矩 | 转速 | 输出功率 | 效率 | 时间 |
|----|-------|-------|-------|------|-------|-------|------|-------|
| | V | A | W | N. m | rpm | W | % | S |
| 1 | 24.09 | 1.534 | 36.93 | 0.34 | 408.6 | 14.46 | 39.2 | 0.000 |
| 2 | 24.08 | 1.638 | 39.42 | 0.44 | 406.0 | 18.70 | 47.5 | 3.011 |
| 3 | 24.07 | 2.329 | 55.99 | 0.96 | 391.7 | 39.45 | 70.5 | 5.024 |
| 4 | 24.05 | 2.934 | 70.38 | 1.21 | 383.9 | 48.80 | 69.3 | 7.036 |
| 5 | 24.03 | 3.319 | 79.53 | 1.44 | 377.6 | 57.01 | 71.7 | 9.049 |
| 6 | 24.02 | 3.762 | 90.20 | 1.69 | 370.1 | 65.56 | 72.7 | 11.06 |
| 7 | 24.01 | 4.207 | 100.7 | 1.97 | 363.0 | 74.72 | 74.2 | 13.07 |
| 8 | 24.00 | 4.680 | 112.1 | 2.26 | 355.5 | 84.27 | 75.1 | 15.09 |
| 9 | 23.98 | 5.187 | 124.2 | 2.57 | 347.6 | 93.53 | 75.3 | 17.10 |
| 10 | 23.96 | 5.772 | 137.9 | 2.92 | 338.7 | 103.6 | 75.1 | 19.11 |
| 11 | 23.95 | 6.344 | 151.4 | 3.28 | 330.4 | 113.4 | 74.9 | 21.12 |
| 12 | 23.93 | 6.941 | 165.8 | 3.64 | 321.6 | 122.7 | 74.0 | 23.14 |
| 13 | 23.91 | 7.625 | 181.9 | 4.05 | 312.0 | 132.4 | 72.8 | 25.15 |

Dc brushless hub motor products

| | | | | | | | | |
|----|-------|-------|-------|------|-------|-------|------|-------|
| 14 | 23.88 | 8.293 | 197.5 | 4.46 | 302.8 | 141.5 | 71.6 | 27.16 |
| 15 | 23.87 | 8.981 | 213.8 | 4.91 | 293.3 | 150.7 | 70.5 | 29.17 |
| 16 | 23.84 | 9.860 | 234.6 | 5.36 | 283.1 | 158.9 | 67.7 | 31.19 |
| 17 | 23.82 | 10.52 | 250.2 | 5.82 | 273.4 | 166.5 | 66.5 | 33.20 |
| 18 | 23.80 | 11.32 | 268.6 | 6.31 | 263.5 | 174.1 | 64.8 | 35.21 |
| 19 | 23.77 | 12.25 | 290.1 | 6.79 | 253.3 | 180.2 | 62.1 | 37.22 |
| 20 | 23.74 | 13.08 | 309.9 | 7.32 | 241.9 | 185.4 | 59.8 | 39.24 |
| 21 | 23.72 | 13.97 | 330.4 | 7.84 | 231.5 | 190.0 | 57.5 | 41.25 |
| 22 | 23.69 | 15.03 | 354.8 | 8.38 | 220.1 | 193.2 | 54.5 | 43.26 |
| 23 | 23.66 | 15.50 | 365.7 | 9.09 | 183.9 | 175.0 | 47.9 | 45.27 |
| 24 | 23.66 | 15.55 | 367.6 | 9.60 | 159.6 | 160.5 | 43.6 | 47.28 |

Test the data waveform: 36v

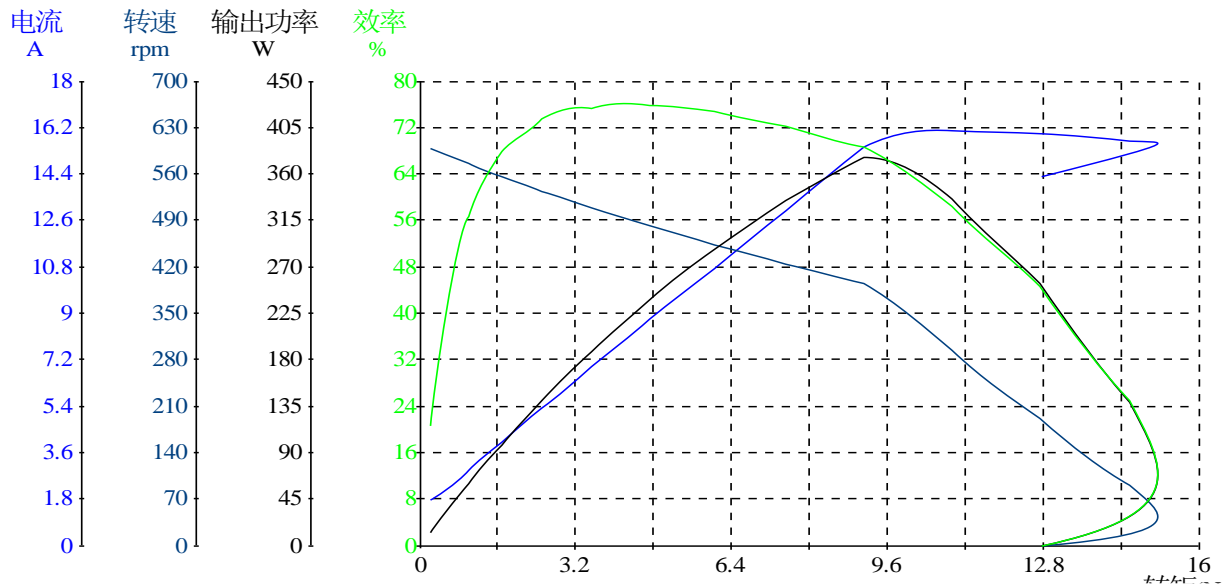

| 特征点 | 电压 | 电流 | 输入功率 | 转矩 | 转速 | 输出功率 | 效率 | 时间 |
|--------------------|-------|-------|-------|-------|-------|-------|------|-------|
| | V | A | W | N. m | rpm | W | % | S |
| 不加载点 (No_Load) | 36.15 | 1.740 | 62.85 | 0.21 | 598.1 | 12.90 | 20.5 | 0.000 |
| 最高效率点 (Eff_max) | 35.95 | 8.086 | 290.1 | 4.30 | 491.4 | 221.2 | 76.3 | 29.17 |
| 最大输出功率点 (Pout_max) | 35.73 | 15.46 | 550.0 | 9.13 | 393.9 | 376.5 | 68.5 | 49.30 |
| 最大转矩点 (Torque_max) | 35.72 | 15.76 | 560.3 | 15.93 | 18.7 | 31.18 | 5.6 | 71.43 |
| 结束点 (End) | 35.76 | 14.31 | 511.2 | 12.77 | 0 | 0 | 0 | 73.45 |

Dynamometer report data: 36v

| 序号 | 电压 | 电流 | 输入功率 | 转矩 | 转速 | 输出功率 | 效率 | 时间 |
|----|-------|-------|-------|------|-------|-------|------|-------|
| | V | A | W | N. m | rpm | W | % | S |
| 1 | 36.15 | 1.740 | 62.85 | 0.21 | 598.1 | 12.90 | 20.5 | 0.000 |
| 2 | 36.15 | 1.812 | 65.45 | 0.28 | 596.7 | 17.74 | 27.1 | 3.011 |

Dc brushless hub motor products

| | | | | | | | | |
|----|-------|-------|-------|-------|-------|-------|------|-------|
| 3 | 36.14 | 2.369 | 85.52 | 0.77 | 582.5 | 46.96 | 54.9 | 5.023 |
| 4 | 36.11 | 2.901 | 104.7 | 0.99 | 575.4 | 59.40 | 56.7 | 7.036 |
| 5 | 36.10 | 3.230 | 116.5 | 1.19 | 569.3 | 71.17 | 61.1 | 9.048 |
| 6 | 36.09 | 3.617 | 130.5 | 1.43 | 562.6 | 84.12 | 64.5 | 11.06 |
| 7 | 36.08 | 3.999 | 143.9 | 1.68 | 556.2 | 97.72 | 67.9 | 13.07 |
| 8 | 36.07 | 4.394 | 158.4 | 1.93 | 548.9 | 111.1 | 70.2 | 15.09 |
| 9 | 36.07 | 4.921 | 177.3 | 2.22 | 541.3 | 125.9 | 71.0 | 17.10 |
| 10 | 36.07 | 5.320 | 191.5 | 2.52 | 533.7 | 140.8 | 73.5 | 19.11 |
| 11 | 36.06 | 5.803 | 208.7 | 2.85 | 525.8 | 156.8 | 75.1 | 21.12 |
| 12 | 36.04 | 6.306 | 226.7 | 3.17 | 517.7 | 171.6 | 75.7 | 23.14 |
| 13 | 35.99 | 6.945 | 249.4 | 3.53 | 508.7 | 187.8 | 75.3 | 25.15 |
| 14 | 35.97 | 7.503 | 269.0 | 3.92 | 500.1 | 205.0 | 76.2 | 27.16 |
| 15 | 35.95 | 8.086 | 290.1 | 4.30 | 491.4 | 221.2 | 76.3 | 29.17 |
| 16 | 35.93 | 8.744 | 313.6 | 4.71 | 481.8 | 237.8 | 75.8 | 31.19 |
| 17 | 35.91 | 9.380 | 335.8 | 5.15 | 472.7 | 254.9 | 75.9 | 33.20 |
| 18 | 35.89 | 10.03 | 359.1 | 5.57 | 463.5 | 270.5 | 75.3 | 35.21 |
| 19 | 35.87 | 10.72 | 384.0 | 6.04 | 453.9 | 287.1 | 74.8 | 37.22 |
| 20 | 35.85 | 11.49 | 410.8 | 6.52 | 443.8 | 302.9 | 73.7 | 39.23 |
| 21 | 35.83 | 12.22 | 436.6 | 7.00 | 434.3 | 318.4 | 72.9 | 41.25 |
| 22 | 35.80 | 12.99 | 463.9 | 7.53 | 424.6 | 334.9 | 72.2 | 43.26 |
| 23 | 35.78 | 13.83 | 493.4 | 8.06 | 414.0 | 349.3 | 70.8 | 45.27 |
| 24 | 35.76 | 14.64 | 521.8 | 8.58 | 404.0 | 362.9 | 69.5 | 47.28 |
| 25 | 35.73 | 15.46 | 550.0 | 9.13 | 393.9 | 376.5 | 68.5 | 49.30 |
| 26 | 35.71 | 16.08 | 570.8 | 9.81 | 365.7 | 375.7 | 65.8 | 51.31 |
| 27 | 35.70 | 16.13 | 575.4 | 10.39 | 328.1 | 357.1 | 62.0 | 53.32 |
| 28 | 35.70 | 16.10 | 574.4 | 10.95 | 293.1 | 336.2 | 58.5 | 55.33 |
| 29 | 35.71 | 16.04 | 572.6 | 11.59 | 249.1 | 302.3 | 52.8 | 57.35 |
| 30 | 35.71 | 16.00 | 571.0 | 12.13 | 223.0 | 283.1 | 49.6 | 59.36 |
| 31 | 35.71 | 15.93 | 568.7 | 12.73 | 190.2 | 253.5 | 44.6 | 61.37 |
| 32 | 35.71 | 15.89 | 567.4 | 13.40 | 148.6 | 208.5 | 36.8 | 63.38 |
| 33 | 35.72 | 15.76 | 563.0 | 14.03 | 113.7 | 167.1 | 29.7 | 65.40 |
| 34 | 35.72 | 15.68 | 560.3 | 14.58 | 91.0 | 138.9 | 24.8 | 67.41 |
| 35 | 35.72 | 15.60 | 557.2 | 15.29 | 46.3 | 74.10 | 13.3 | 69.42 |
| 36 | 35.72 | 15.76 | 560.3 | 15.93 | 18.7 | 31.18 | 5.6 | 71.43 |
| 37 | 35.76 | 14.31 | 511.2 | 12.77 | 0 | 0 | 0 | 73.45 |

Test the data waveform: 48

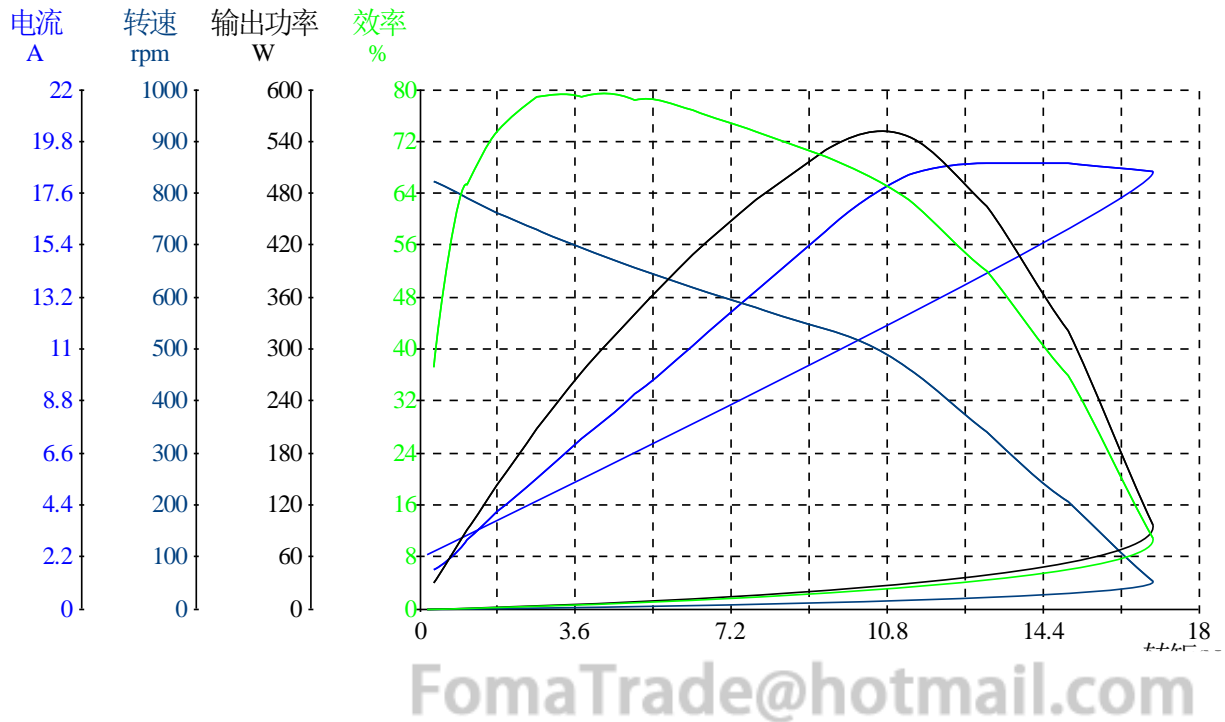

| 特征点 | 电压 | 电流 | 输入功率 | 转矩 | 转速 | 输出功率 | 效率 | 时间 |
|-------------------|-------|-------|-------|-------|-------|-------|------|-------|
| | V | A | W | N. m | rpm | W | % | S |
| 不加载点(No_Load) | 48.12 | 1.644 | 78.93 | 0.34 | 823.6 | 29.32 | 37.1 | 0.000 |
| 最高效率点(Eff_max) | 47.94 | 7.742 | 370.4 | 4.14 | 681.5 | 295.4 | 79.7 | 27.16 |
| 最大输出功率点(Pout_max) | 47.61 | 17.77 | 845.1 | 10.56 | 507.1 | 560.9 | 66.4 | 53.32 |
| 最大转矩点(Torque_max) | 47.59 | 17.47 | 829.1 | 17.25 | 9.7 | 17.52 | 2.1 | 75.46 |
| 结束点(End) | 48.08 | 2.251 | 107.7 | 0.17 | 0 | 0 | 0 | 77.47 |

Dynamometer report data: 48v

| 序号 | 电压 | 电流 | 输入功率 | 转矩 | 转速 | 输出功率 | 效率 | 时间 |
|----|-------|-------|-------|------|-------|-------|------|-------|
| | V | A | W | N. m | rpm | W | % | S |
| 1 | 48.12 | 1.644 | 78.93 | 0.34 | 823.6 | 29.32 | 37.1 | 0.000 |
| 2 | 48.12 | 1.749 | 83.94 | 0.44 | 819.8 | 38.11 | 45.4 | 3.011 |
| 3 | 48.10 | 2.354 | 113.1 | 0.90 | 799.7 | 75.52 | 66.8 | 5.023 |
| 4 | 48.08 | 2.907 | 139.6 | 1.10 | 789.9 | 91.30 | 65.4 | 7.036 |
| 5 | 48.07 | 3.252 | 156.2 | 1.31 | 781.6 | 106.9 | 68.4 | 9.048 |
| 6 | 48.06 | 3.663 | 175.8 | 1.56 | 772.0 | 126.3 | 71.8 | 11.06 |
| 7 | 48.05 | 4.084 | 195.9 | 1.80 | 761.6 | 143.7 | 73.4 | 13.07 |
| 8 | 48.04 | 4.516 | 216.7 | 2.09 | 751.5 | 164.3 | 75.8 | 15.09 |

Dc brushless hub motor products

| | | | | | | | | |
|----|-------|-------|-------|-------|-------|-------|------|-------|
| 9 | 48.02 | 5.013 | 240.2 | 2.39 | 740.3 | 185.4 | 77.2 | 17.10 |
| 10 | 48.01 | 5.503 | 263.4 | 2.72 | 729.5 | 207.4 | 78.8 | 19.11 |
| 11 | 47.99 | 6.007 | 287.7 | 3.02 | 718.4 | 227.2 | 79.0 | 21.12 |
| 12 | 47.97 | 6.556 | 314.0 | 3.37 | 706.2 | 249.5 | 79.5 | 23.14 |
| 13 | 47.95 | 7.231 | 346.3 | 3.76 | 693.6 | 272.8 | 78.8 | 25.15 |
| 14 | 47.94 | 7.742 | 370.4 | 4.14 | 681.5 | 295.4 | 79.7 | 27.16 |
| 15 | 47.92 | 8.357 | 399.6 | 4.53 | 669.6 | 317.7 | 79.5 | 29.17 |
| 16 | 47.87 | 9.107 | 435.3 | 4.96 | 656.5 | 340.9 | 78.3 | 31.19 |
| 17 | 47.86 | 9.677 | 461.6 | 5.42 | 644.0 | 365.3 | 79.1 | 33.20 |
| 18 | 47.83 | 10.44 | 497.8 | 5.84 | 631.1 | 386.1 | 77.6 | 35.21 |
| 19 | 47.81 | 11.14 | 531.7 | 6.31 | 618.9 | 408.6 | 76.9 | 37.22 |
| 20 | 47.79 | 11.93 | 568.4 | 6.78 | 605.3 | 429.9 | 75.6 | 39.23 |
| 21 | 47.77 | 12.68 | 604.0 | 7.28 | 592.3 | 451.7 | 74.8 | 41.25 |
| 22 | 47.74 | 13.45 | 641.0 | 7.78 | 579.4 | 472.0 | 73.6 | 43.26 |
| 23 | 47.72 | 14.31 | 680.9 | 8.31 | 565.4 | 491.8 | 72.2 | 45.27 |
| 24 | 47.69 | 15.14 | 720.3 | 8.85 | 552.1 | 511.3 | 71.0 | 47.28 |
| 25 | 47.67 | 16.00 | 761.3 | 9.39 | 538.4 | 529.5 | 69.6 | 49.30 |
| 26 | 47.64 | 16.88 | 802.3 | 9.94 | 525.0 | 546.3 | 68.1 | 51.31 |
| 27 | 47.61 | 17.77 | 845.1 | 10.56 | 507.1 | 560.9 | 66.4 | 53.32 |
| 28 | 47.59 | 18.39 | 868.1 | 11.31 | 461.3 | 546.1 | 62.9 | 55.33 |
| 29 | 47.57 | 18.73 | 890.0 | 11.88 | 429.7 | 534.4 | 60.0 | 57.35 |
| 30 | 47.57 | 18.88 | 897.5 | 12.54 | 374.2 | 491.1 | 54.7 | 59.36 |
| 31 | 47.57 | 18.88 | 897.5 | 13.10 | 339.3 | 465.4 | 51.9 | 61.37 |
| 32 | 47.57 | 18.89 | 898.1 | 13.70 | 297.1 | 426.0 | 47.4 | 63.38 |
| 33 | 47.57 | 18.88 | 897.6 | 14.39 | 239.3 | 360.4 | 40.2 | 65.40 |
| 34 | 47.57 | 18.85 | 896.4 | 14.97 | 205.1 | 321.5 | 35.9 | 67.41 |
| 35 | 47.58 | 18.74 | 891.2 | 15.59 | 158.1 | 258.1 | 29.0 | 69.42 |
| 36 | 47.58 | 18.67 | 888.0 | 16.31 | 96.7 | 165.1 | 18.6 | 71.43 |
| 37 | 47.59 | 18.55 | 882.9 | 16.93 | 54.2 | 96.08 | 10.9 | 73.45 |
| 38 | 47.59 | 17.47 | 829.1 | 17.25 | 9.7 | 17.52 | 2.1 | 75.46 |
| 39 | 48.08 | 2.251 | 107.7 | 0.17 | 0 | 0 | 0 | 77.47 |

FomaTrade@hotmail.com

Electrical wiring definition:

- 1、 the default definition of phase line; yellow(U) blue(V) green(W)、



图1: 电气原理图
The Electrical Principle Diagram

- 2、 Hall line; red(VCC) yellow(HA) blue(HB) 绿 green(HC) 黑 black(GND)

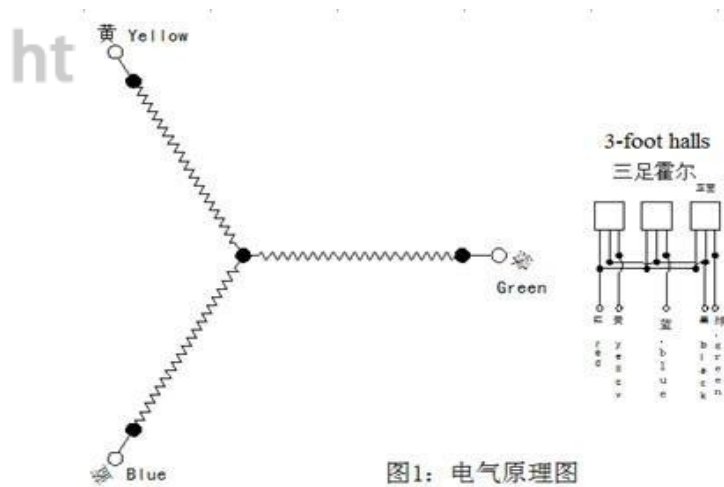
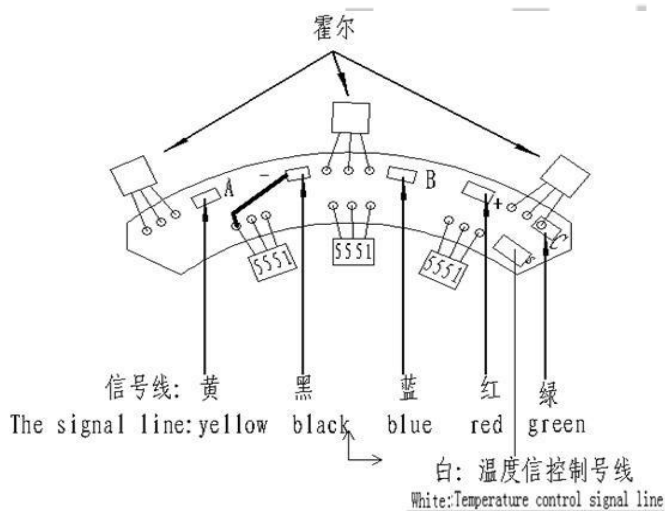

- 3、 The motor (external) rotor is a permanent magnet, integrated with the wheel hub.
- 4、 the three power cables are connected with the winding, generally using 1.0-4.0mm² high temperature line, the number line on the Hall element is 0.1-0.3mm² high temperature line.
- 5、 In the schematic diagram, "●" is the internal node, which is connected by the manufacturing plant, and "○" is the external node, which is connected by the customer.

- 6、 The power supply applicable to this product is: DC24V~DC100V power supply or lithium battery.
- 7、 when the electrical Angle of the drive output is not the same, the motor is stuck, the rotation is abnormal and there is noise, the motor is relatively hot, and the Hall line sequence or phase line sequence of the motor can be changed to achieve the electrical Angle change.
- 8、 check whether the appearance is damaged, check whether the wiring harness is broken。
- 9、 before powering on, please ensure that the drive controller and the motor are connected correctly, and ensure that the power supply voltage is within the specified range. If the operation is not as required, there may be a risk of burning out.
- 10、 For your safety, please detach the hub motor from the ground when powering on for the first time, keep the motor suspended, and then power on the drive (select according to the matching motor, start the drive motor is powered on or stuck and abnormal temperature rise, please disconnect the motor in time within 3 seconds to avoid burning the motor sensor coil).
- 11、 Phase line, Hall line, the corresponding function color pair is connected to the interface on the corresponding driver, if the motor is stuck or abnormal rotation after the drive is powered on, the heat is relatively high, you can adjust the phase line, Hall line ordering, change the Angle of the electric machine a total of 36 kinds of connection, such as 36 kinds of adjustment or abnormal, you must contact the drive adjustment system

- 12、 before powering on, please ensure that the controller and the motor are connected correctly, and ensure that the power supply voltage is within the specified range. For your safety, please lift the hub motor off the ground when powering on for the first time, keep the motor suspended, and then power on the drive (select according to the matching motor, start the drive motor has a current card, please power off within 3 seconds

Brake system configuration

1. Electronic brake; D1 (unilateral exit shaft), S1 (bilateral exit shaft) configuration standard, is attracted to each other through the magnetic field, generated a resistance called electronic brake

2. Disc brake; D2 (unilateral exit shaft), S2 (bilateral exit shaft) configuration standard, is through one end cap

There is a fixed disc brake, and the brake is realized by adding resistance to the disc brake through the mechanical structure

3. Hub brake; D3 (single exit axle), S3 (double exit axle) configuration standard, is through one end cap hub A hub brake disc is formed, and the brake disc is subjected to resistance by mechanical structure.

common parameter

Motor maximum RPM: According to the highest speed of the motor and the highest speed required by the user. Given speed

Do not exceed the maximum motor speed.

Maximum motor current: This refers to the maximum current of the motor, which generally corresponds to the maximum peak value of the motor

The current cannot exceed the maximum current specified by the motor type.

Motor movement direction: motor movement forward and backward direction switching is completely synchronous without difference.

Sensor class: 霍尔 (HALL)

<https://electricassistcart.com>

installation notice

1. Connect the motor to the controller and power supply according to the wiring diagram on the controller.

2. The motor installs tires outside the outer rotor hub.

3. The power cord passes through the metal parts and is protected by non-metal products.

4. Do not turn when turning: the power cord is not firmly installed - rewire;

5. Motor normal noise: Hall component is bad - replace.

6. Pay special attention to when the motor is powered on, the motor is not moving or stuck, and the abnormal heat is relatively fast

Within three seconds must be disconnected and adjusted electrical Angle or drive output to avoid motor failure

7. Contact the after-sales service for more questions

It is forbidden for third parties to reprint, copy, steal or sell documents without permission

The document is for reference only. If there is any editing error, the company will not bear any responsibility

The documents are internal information, and the company does not bear any legal responsibility if the use infringes the rights of others