

<https://electricassistcart.com>

# 海南金海芯科技控股有限公司

Hainan Jinhaixin Technology Holdings Co., Ltd

[FomaTrade@outlook.com](mailto:FomaTrade@outlook.com)

## 产品手册

## Product manual

[FomaTrade@hotmail.com](mailto:FomaTrade@hotmail.com)

编制(Edit): 李工 (li)

审核(Check): 杨工 (yang)

<https://electricassistcart.com>

批准(Approval): 杨先生 (R' yang)

[FomaTrade@outlook.com](mailto:FomaTrade@outlook.com)

2024年01月01日

May, 01, 2024

-----由深圳市金海芯控股有限公司技术支持版权所有-----

[FomaTrade@hotmail.com](mailto:FomaTrade@hotmail.com)

Technical support by Shenzhen Jinhaixin Holdings Co., Ltd. All rights reserved



**Product name:** DC brushless gearless motor

**Specification Model:** 6.5-inch twin shaft diameter  
172mm tire width 45mm  
Open 76mm (threaded type)

**Product coded:** FomaTrade-24046D504163536S1-001

# Motor structure combination diagram:

## <<MOTOR STRUCTURE>>

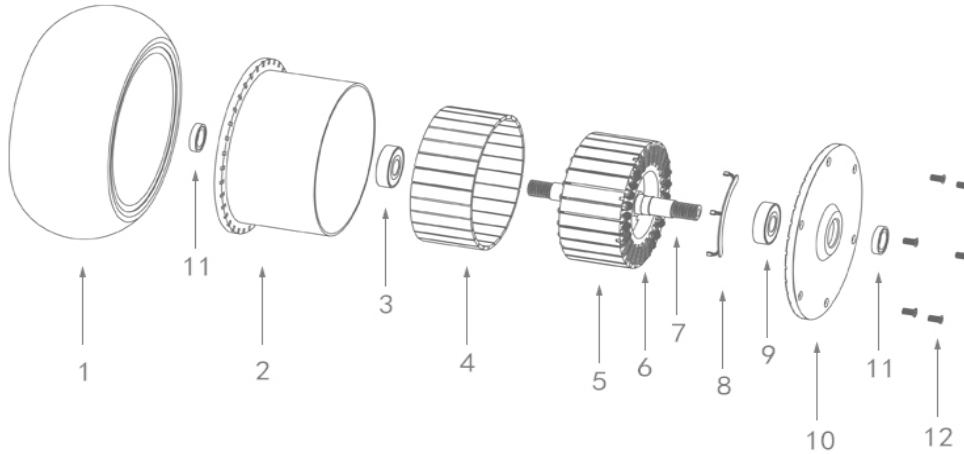

1: TIRE 2: WHEEL HUB 3: OUTER BEARING 4: MAGNET 5: STATOR 6: COPPER WIRE

7: FIXED SHAFT 8: SENSOR 9: OUTER BEARING 10: INNER END COVER 11: SCREW 12: WIPER RING

## Motor dimensional drawing:

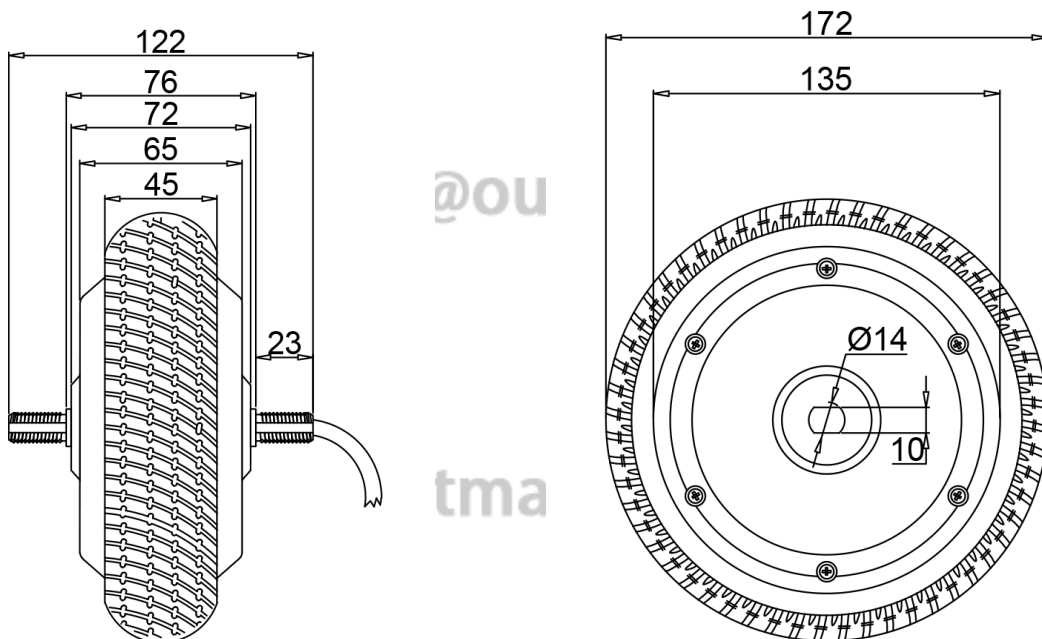

# Test the data waveform: 24v

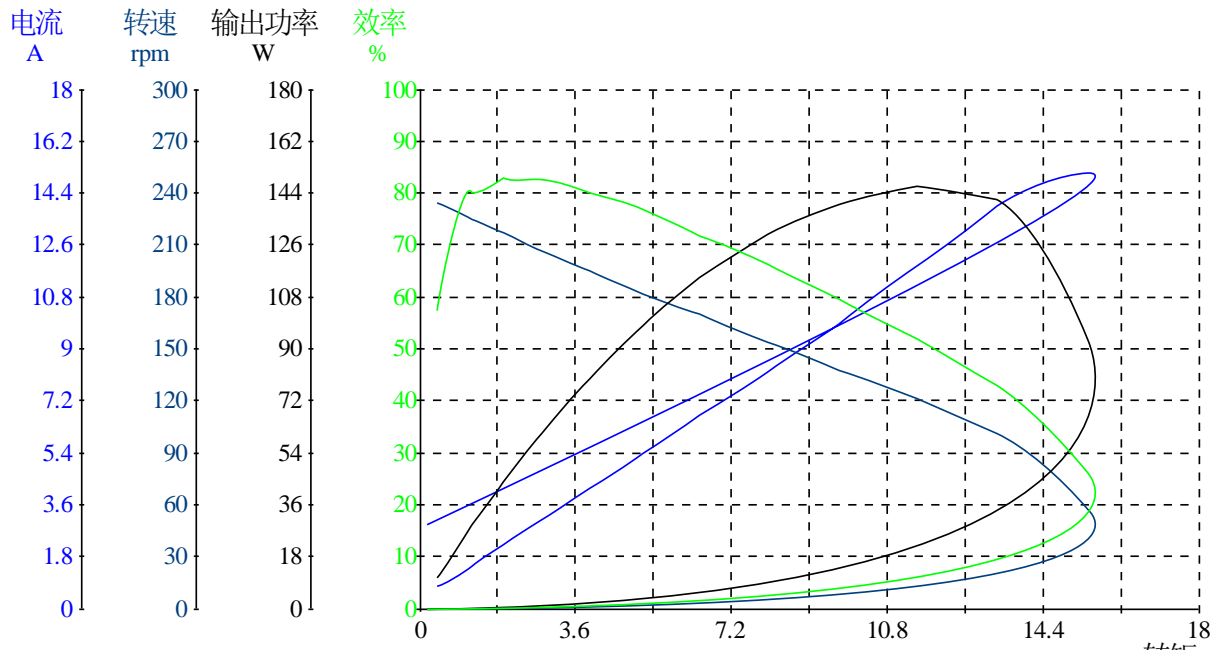

FomaTrade@hotmail.com

特征点	电压	电流	输入功率	转矩	转速	输出功率	效率	时间
	V	A	W	N. m	rpm	W	%	S
不加载点(No_Load)	24.14	0.750	18.10	0.42	234.7	10.37	57.3	0.000
最高效率点(Eff_max)	24.14	1.213	29.24	1.03	227.5	24.49	83.7	5.024
最大输出功率点(Pout_max)	23.83	11.88	282.2	11.48	121.6	146.2	51.8	55.33
最大转矩点(Torque_max)	23.73	15.11	358.2	16.09	40.7	68.58	19.1	69.42
结束点(End)	24.08	2.930	69.84	0.19	0	0	0	73.45

# Dynamometer report data: 24v

序号	电压	电流	输入功率	转矩	转速	输出功率	效率	时间
	V	A	W	N. m	rpm	W	%	S
1	24.14	0.750	18.10	0.42	234.7	10.37	57.3	0.000
2	24.15	0.803	19.33	0.51	233.7	12.43	64.3	3.011
3	24.14	1.213	29.24	1.03	227.5	24.49	83.7	5.024
4	24.13	1.494	36.02	1.22	225.2	28.77	79.9	7.036
5	24.12	1.734	41.78	1.43	222.8	33.40	80.0	9.048
6	24.12	1.979	47.66	1.69	219.4	38.87	81.5	11.06
7	24.11	2.196	52.80	1.93	216.8	43.72	82.8	13.07
8	24.10	2.497	60.03	2.20	213.9	49.31	82.1	15.09
9	24.09	2.782	66.83	2.52	209.8	55.44	83.0	17.10

## Dc brushless hub motor products

10	24.08	3.068	73.74	2.81	206.8	60.89	82.6	19.11
11	24.07	3.430	82.30	3.19	202.6	67.67	82.2	21.12
12	24.06	3.770	90.42	3.53	198.9	73.60	81.4	23.14
13	24.05	4.151	99.69	3.92	194.7	79.87	80.1	25.15
14	24.04	4.529	108.6	4.31	190.7	86.01	79.2	27.16
15	24.03	4.917	117.9	4.73	186.4	92.31	78.3	29.17
16	24.01	5.357	128.1	5.16	182.0	98.25	76.7	31.19
17	24.00	5.782	138.3	5.60	177.6	104.1	75.3	33.20
18	23.99	6.224	148.9	6.06	173.1	109.8	73.7	35.21
19	23.98	6.678	159.9	6.45	170.0	114.7	71.8	37.22
20	23.96	7.192	172.0	7.04	163.5	120.5	70.0	39.24
21	23.95	7.686	183.6	7.53	158.6	125.0	68.1	41.25
22	23.93	8.204	195.8	8.05	153.9	129.8	66.3	43.26
23	23.92	8.838	210.7	8.61	148.7	134.0	63.6	45.27
24	23.90	9.314	221.9	9.14	143.2	137.1	61.8	47.28
25	23.89	9.880	234.8	9.70	137.9	140.1	59.7	49.30
26	23.87	10.59	252.3	10.30	132.5	142.9	56.6	51.31
27	23.84	11.22	266.6	10.89	127.1	144.9	54.4	53.32
28	23.83	11.88	282.2	11.48	121.6	146.2	51.8	55.33
29	23.81	12.53	297.6	12.09	114.9	145.4	48.9	57.35
30	23.79	13.21	312.8	12.72	107.9	143.7	45.9	59.36
31	23.77	13.92	329.7	13.34	101.4	141.6	43.0	61.37
32	23.75	14.58	345.4	14.00	93.0	136.3	39.5	63.38
33	23.73	15.04	356.3	14.78	75.8	117.3	32.9	65.40
34	23.72	15.11	357.6	15.45	57.4	92.85	26.0	67.41
35	23.73	15.11	358.2	16.09	40.7	68.58	19.1	69.42
36	23.75	13.80	327.8	15.52	1.5	2.437	0.7	71.43
37	24.08	2.930	69.84	0.19	0	0	0	73.45

FomaTrade@hotmail.com

# Test the data waveform: 36v

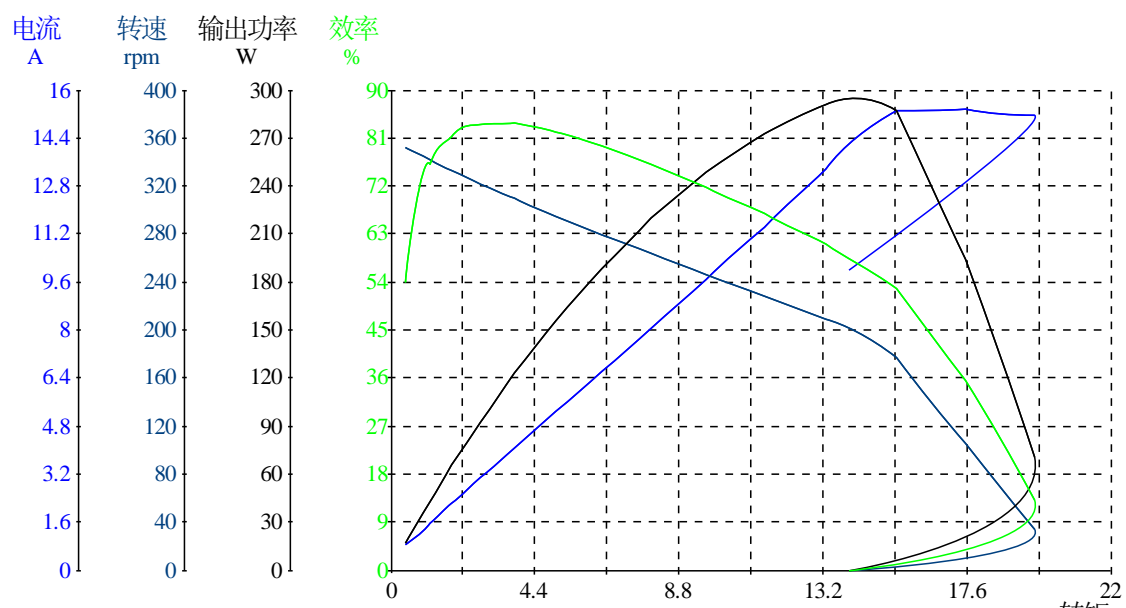

特征点	电压	电流	输入功率	转矩	转速	输出功率	效率	时间
	V	A	W	N. m	rpm	W	%	S
不加载点 (No_Load)	36.09	0.836	30.16	0.44	352.2	16.30	54.0	0.000
最高效率点 (Eff_max)	36.03	4.077	146.5	3.79	309.6	122.9	83.9	25.15
最大输出功率点 (Pout_max)	35.69	14.82	527.6	14.62	194.4	297.6	56.4	65.40
最大转矩点 (Torque_max)	35.68	14.82	528.6	20.08	9.4	19.77	3.7	81.50
结束点 (End)	35.84	9.981	356.4	14.00	0	0	0	83.51

## Dynamometer report data: 36v

序号	电压	电流	输入功率	转矩	转速	输出功率	效率	时间
	V	A	W	N. m	rpm	W	%	S
1	36.09	0.836	30.16	0.44	352.2	16.30	54.0	0.000
2	36.09	0.888	32.04	0.51	351.2	18.83	58.8	3.011
3	36.09	1.222	44.09	0.96	345.6	34.81	78.9	5.023
4	36.07	1.555	56.03	1.19	342.0	42.61	76.1	7.036
5	36.06	1.758	63.29	1.43	338.6	50.70	80.1	9.048
6	36.06	1.995	71.81	1.63	336.0	57.20	79.7	11.06
7	36.05	2.230	80.26	1.87	332.9	65.18	81.2	13.07
8	36.05	2.485	89.36	2.18	328.7	74.89	83.8	15.09
9	36.03	2.819	101.4	2.48	325.0	84.25	83.1	17.10
10	36.03	3.072	110.6	2.74	321.7	92.29	83.5	19.11
11	36.03	3.423	122.8	3.10	317.1	102.9	83.8	21.12
12	36.03	3.776	135.8	3.46	312.7	113.3	83.4	23.14

## Dc brushless hub motor products

13	36.03	4.077	146.5	3.79	309.6	122.9	83.9	25.15
14	36.02	4.484	161.0	4.21	303.9	134.0	83.2	27.16
15	36.00	4.867	174.8	4.62	299.3	144.9	82.9	29.17
16	35.99	5.300	190.2	5.06	294.3	155.9	82.0	31.19
17	35.98	5.718	204.9	5.51	289.5	167.1	81.6	33.20
18	35.96	6.149	220.7	5.96	284.4	177.6	80.5	35.21
19	35.95	6.632	237.5	6.45	279.2	188.6	79.4	37.22
20	35.93	7.096	254.3	6.95	273.9	199.3	78.3	39.24
21	35.92	7.568	271.1	7.46	268.6	209.7	77.3	41.25
22	35.90	8.057	288.7	7.97	263.3	219.8	76.1	43.26
23	35.88	8.605	308.0	8.53	257.5	229.9	74.6	45.27
24	35.87	9.128	326.9	9.08	251.8	239.5	73.3	47.28
25	35.86	9.667	346.1	9.64	246.3	248.6	71.8	49.30
26	35.83	10.34	369.7	10.23	240.1	257.2	69.6	51.31
27	35.82	10.84	387.2	10.81	234.3	265.2	68.5	53.32
28	35.80	11.42	407.7	11.42	228.2	272.8	66.9	55.33
29	35.77	12.16	433.9	12.05	221.7	279.7	64.5	57.35
30	35.76	12.71	453.3	12.67	215.5	285.8	63.1	59.36
31	35.74	13.35	475.3	13.30	209.0	291.0	61.2	61.37
32	35.71	14.11	502.4	13.80	204.9	296.1	58.9	63.38
33	35.69	14.82	527.6	14.62	194.4	297.6	56.4	65.40
34	35.67	15.31	542.6	15.46	177.2	286.9	52.9	67.41
35	35.67	15.33	547.4	16.16	151.7	256.7	46.9	69.42
36	35.67	15.30	545.5	16.89	125.5	222.0	40.7	71.43
37	35.67	15.34	546.4	17.59	105.2	193.7	35.5	73.45
38	35.67	15.22	543.8	18.28	81.0	155.0	28.5	75.46
39	35.68	15.16	540.8	18.99	57.4	114.1	21.1	77.47
40	35.68	15.14	539.1	19.70	34.0	70.12	13.0	79.48
41	35.68	14.82	528.6	20.08	9.4	19.77	3.7	81.50
42	35.84	9.981	356.4	14.00	0	0	0	83.51

FomaTrade@hotmail.com

# Test the data waveform: 48

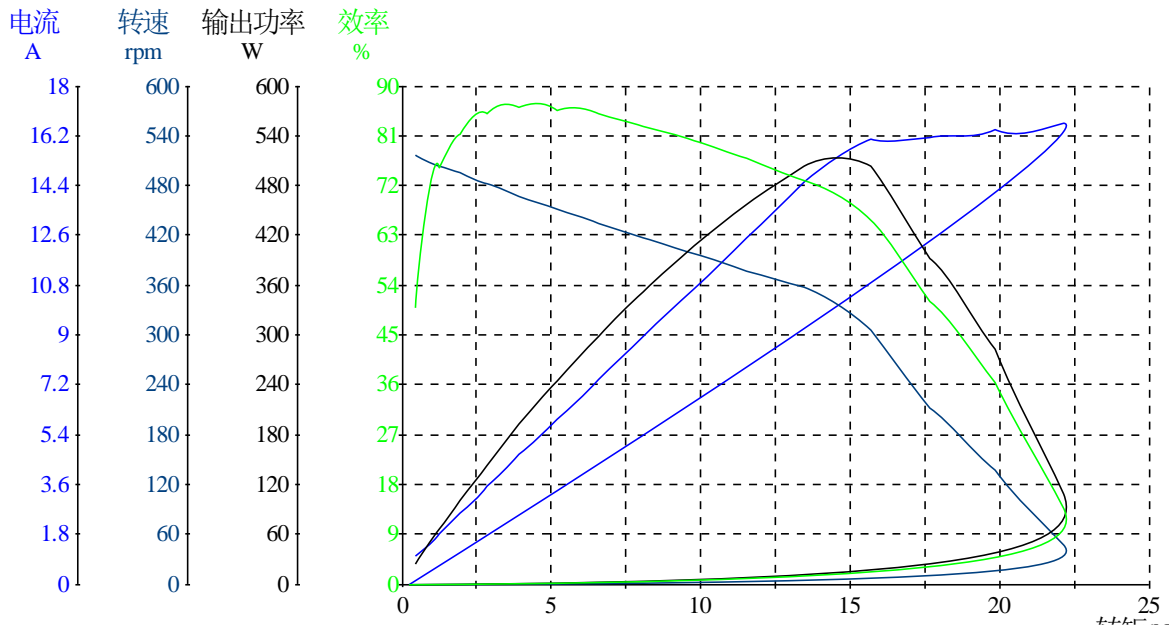

特征点	电压	电流	输入功率	转矩	转速	输出功率	效率	时间
	V	A	W	N. m	rpm	W	%	S
不加载点 (No_Load)	48.04	0.985	47.29	0.44	516.1	23.67	50.0	0.000
最高效率点 (Eff_max)	47.90	5.464	261.1	4.76	457.7	228.2	87.4	29.17
最大输出功率点 (Pout_max)	47.59	15.77	743.7	14.98	329.0	515.9	69.4	65.40
最大转矩点 (Torque_max)	47.56	16.59	785.8	22.91	16.7	40.06	5.1	87.53
结束点 (End)	48.06	0.000	0.000	0.22	0	0	0	91.56

## Dynamometer report data: 48v

序号	电压	电流	输入功率	转矩	转速	输出功率	效率	时间
	V	A	W	N. m	rpm	W	%	S
1	48.04	0.985	47.29	0.44	516.1	23.67	50.0	0.000
2	48.03	1.051	50.43	0.53	515.0	28.47	56.5	3.011
3	48.02	1.453	69.72	1.06	505.9	56.25	80.7	5.024
4	48.01	1.817	87.16	1.24	503.8	65.51	75.2	7.036
5	48.00	2.048	98.23	1.45	501.3	76.00	77.4	9.048
6	48.00	2.319	111.2	1.72	497.7	89.84	80.8	11.06
7	47.99	2.585	123.9	1.94	494.9	100.5	81.1	13.07
8	47.98	2.865	137.2	2.25	490.1	115.5	84.2	15.09
9	47.97	3.161	151.4	2.56	484.7	130.1	86.0	17.10
10	47.96	3.523	168.6	2.84	482.0	143.4	85.1	19.11
11	47.95	3.873	185.3	3.22	477.4	160.9	86.9	21.12



## Dc brushless hub motor products

12	47.94	4.219	202.0	3.56	471.7	175.7	87.0	23.14
13	47.93	4.681	223.6	3.94	466.2	192.2	86.0	25.15
14	47.92	5.035	240.7	4.33	461.9	209.3	87.0	27.16
15	47.90	5.464	261.1	4.76	457.7	228.2	87.4	29.17
16	47.89	5.973	285.6	5.18	451.3	244.6	85.6	31.19
17	47.88	6.362	304.4	5.63	445.6	262.6	86.3	33.20
18	47.87	6.838	326.7	6.09	441.0	281.3	86.1	35.21
19	47.85	7.374	351.6	6.56	434.7	298.7	84.9	37.22
20	47.83	7.913	377.5	7.07	428.5	317.4	84.1	39.24
21	47.81	8.437	402.0	7.58	423.2	335.9	83.5	41.25
22	47.80	8.944	426.3	8.09	416.2	352.4	82.7	43.26
23	47.78	9.551	454.5	8.66	410.9	372.4	81.9	45.27
24	47.76	10.08	479.3	9.20	403.5	388.8	81.1	47.28
25	47.75	10.67	507.9	9.77	398.2	407.2	80.2	49.30
26	47.73	11.24	534.7	10.35	391.1	423.7	79.2	51.31
27	47.71	11.90	566.8	10.95	385.0	441.6	77.9	53.32
28	47.69	12.50	593.5	11.56	377.4	456.8	77.0	55.33
29	47.67	13.15	626.1	12.17	371.8	473.6	75.6	57.35
30	47.65	13.85	658.4	12.81	363.9	488.1	74.1	59.36
31	47.63	14.50	689.0	13.44	357.2	502.8	73.0	61.37
32	47.61	15.16	719.1	14.14	348.3	515.7	71.7	63.38
33	47.59	15.77	743.7	14.98	329.0	515.9	69.4	65.40
34	47.58	16.07	764.4	15.70	306.1	503.3	65.8	67.41
35	47.58	15.90	756.8	16.24	281.1	478.1	63.2	69.42
36	47.58	16.05	764.7	16.99	241.7	429.8	56.2	71.43
37	47.58	16.11	767.0	17.68	211.8	392.1	51.1	73.45
38	47.57	16.30	773.7	18.37	194.1	373.4	48.3	75.46
39	47.58	16.02	762.9	19.07	160.2	319.9	41.9	77.47
40	47.57	16.40	779.2	19.84	136.2	282.9	36.3	79.48
41	47.57	16.10	766.7	20.62	99.9	215.7	28.1	81.50
42	47.58	16.43	780.5	21.35	77.2	172.5	22.1	83.51
43	47.56	16.67	792.3	22.16	46.9	108.8	13.7	85.52
44	47.56	16.59	785.8	22.91	16.7	40.06	5.1	87.53
45	47.65	12.95	615.1	19.37	1.2	2.433	0.4	89.55
46	48.06	0.000	0.000	0.22	0	0	0	91.56

## Electrical wiring definition:

- 1、 the default definition of phase line; yellow(U) blue(V) green(W)、



图1: 电气原理图  
The Electrical Principle Diagram

- 2、 Hall line; red(VCC) yellow(HA) blue(HB) 绿 green(HC) 黑 black(GND)

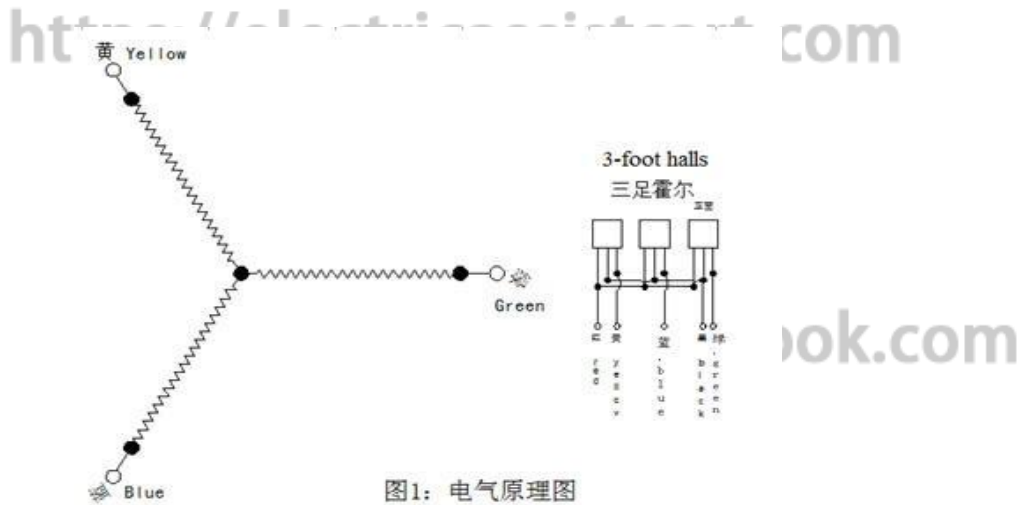
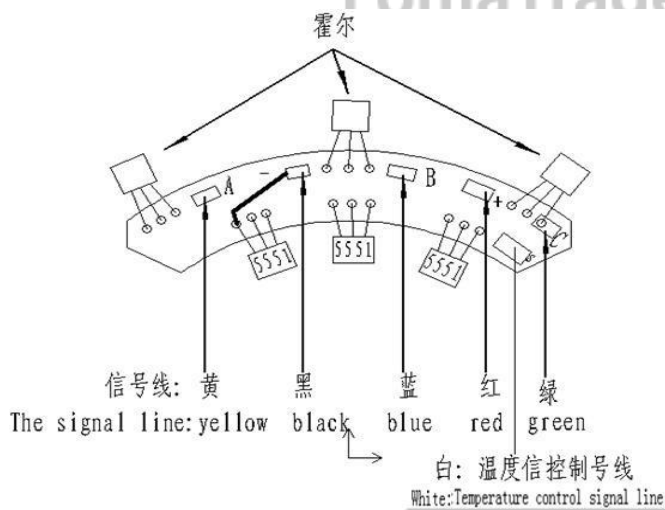

- 3、 The motor (external) rotor is a permanent magnet, integrated with the wheel hub.

- 4、 the three power cables are connected with the winding, generally using 1.0-4.0mm<sup>2</sup> high temperature line, the number line on the Hall element is 0.1-0.3mm<sup>2</sup> high temperature line.

- 5、 In the schematic diagram, "●" is the internal node, which is connected by the manufacturing plant, and "○" is the external node, which is connected by the customer.

- 6、 The power supply applicable to this product is: DC24V~DC100V power supply or lithium battery.
- 7、 when the electrical Angle of the drive output is not the same, the motor is stuck, the rotation is abnormal and there is noise, the motor is relatively hot, and the Hall line sequence or phase line sequence of the motor can be changed to achieve the electrical Angle change.
- 8、 check whether the appearance is damaged, check whether the wiring harness is broken。
- 9、 before powering on, please ensure that the drive controller and the motor are connected correctly, and ensure that the power supply voltage is within the specified range. If the operation is not as required, there may be a risk of burning out.
- 10、 For your safety, please detach the hub motor from the ground when powering on for the first time, keep the motor suspended, and then power on the drive (select according to the matching motor, start the drive motor is powered on or stuck and abnormal temperature rise, please disconnect the motor in time within 3 seconds to avoid burning the motor sensor coil).
- 11、 Phase line, Hall line, the corresponding function color pair is connected to the interface on the corresponding driver, if the motor is stuck or abnormal rotation after the drive is powered on, the heat is relatively high, you can adjust the phase line, Hall line ordering, change the Angle of the electric machine a total of 36 kinds of connection, such as 36 kinds of adjustment or abnormal, you must contact the drive adjustment system

- 12、 before powering on, please ensure that the controller and the motor are connected correctly, and ensure that the power supply voltage is within the specified range. For your safety, please lift the hub motor off the ground when powering on for the first time, keep the motor suspended, and then power on the drive (select according to the matching motor, start the drive motor has a current card, please power off within 3 seconds

## Brake system configuration

**1. Electronic brake;** D1 (unilateral exit shaft), S1 (bilateral exit shaft) configuration standard, is attracted to each other through the magnetic field, generated a resistance called electronic brake

**2. Disc brake;** D2 (unilateral exit shaft), S2 (bilateral exit shaft) configuration standard, is through one end cap

There is a fixed disc brake, and the brake is realized by adding resistance to the disc brake through the mechanical structure

**3. Hub brake;** D3 (single exit axle), S3 (double exit axle) configuration standard, is through one end cap hub A hub brake disc is formed, and the brake disc is subjected to resistance by mechanical structure.

## common parameter

**Motor maximum RPM:** According to the highest speed of the motor and the highest speed required by the user. Given speed

Do not exceed the maximum motor speed.

**Maximum motor current:** This refers to the maximum current of the motor, which generally corresponds to the maximum peak value of the motor

The current cannot exceed the maximum current specified by the motor type.

**Motor movement direction:** motor movement forward and backward direction switching is completely synchronous without difference.

**Sensor class:** 霍尔 (HALL)

<https://electricassistcart.com>

## installation notice

1. Connect the motor to the controller and power supply according to the wiring diagram on the controller.

2. The motor installs tires outside the outer rotor hub.

3. The power cord passes through the metal parts and is protected by non-metal products.

4. Do not turn when turning: the power cord is not firmly installed - rewire;

5. Motor normal noise: Hall component is bad - replace.

6. Pay special attention to when the motor is powered on, the motor is not moving or stuck, and the abnormal heat is relatively fast

Within three seconds must be disconnected and adjusted electrical Angle or drive output to avoid motor failure

7. Contact the after-sales service for more questions

**It is forbidden for third parties to reprint, copy, steal or sell documents without permission**

**The document is for reference only. If there is any editing error, the company will not bear any responsibility**

**The documents are internal information, and the company does not bear any legal responsibility if the use infringes the rights of others**